

# F L A N G E

# JOINTING Guidebook

Hex Head Bolts  
Nuts  
Stud Bolts  
Washers  
Gaskets

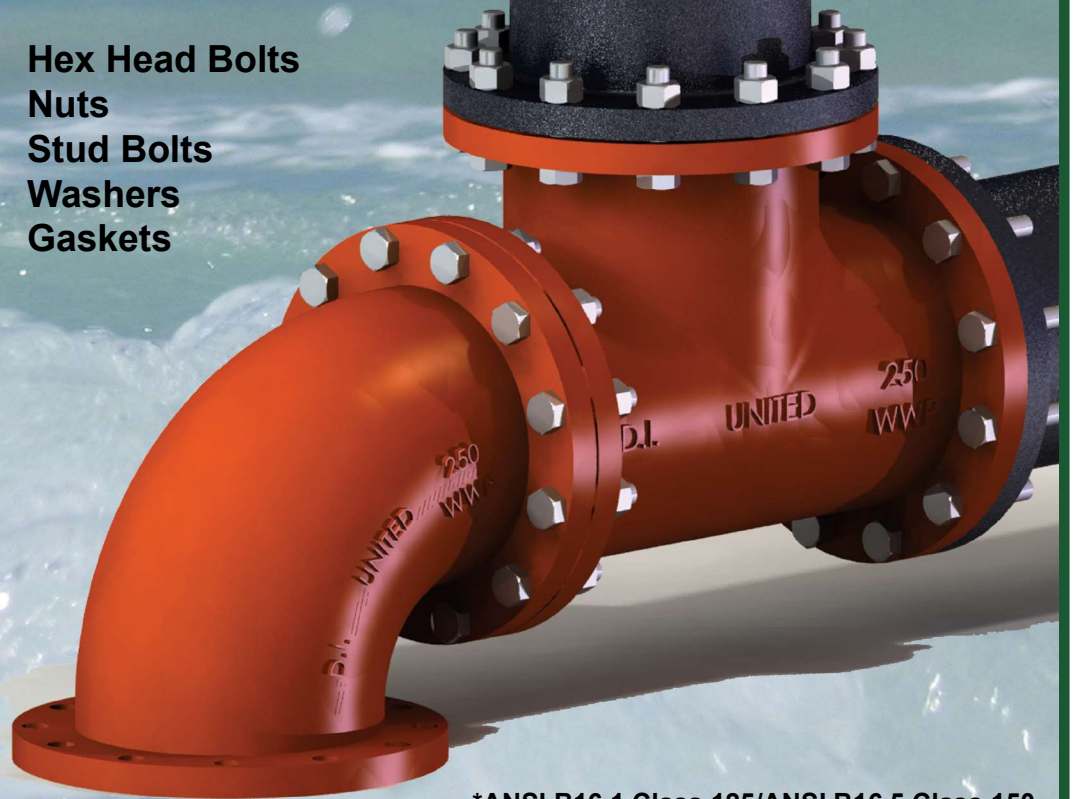

\*ANSI B16.1 Class 125/ANSI B16.5 Class 150  
\*ANSI B16.1 Class 250/ANSI B16.5 Class 300



# FLANGE PRESSURE RATING EXPLANATION

Misunderstandings regarding pressure ratings of flange connections, especially on valves and fittings, are very common. The misunderstandings can be traced back to 1912 when a joint committee of the ASME and the Manufacturer's Committee formulated a standard for flanges and flanged fittings. The Standard covered flanges and flanged fittings produced in gray cast iron and were rated under saturated steam pressures of 125 psi and 250 psi. From those standards, the American National Standards Institute (ANSI) published the B16 Standards.

For example, a 12" class 125 flange produced in gray cast iron @ 100 deg. C to ASME/ANSI B16.1 class 125 has a pressure rating of 184 psi, B16.1 class 250 is rated at 448 psi. That same flange produced in ductile iron is rated by AWWA (American Water Works Assoc.) Standards at 350 psi. That 12" flange in ASME/ANSI B16.5 class 150 (steel flanges) @ 100 deg. C is rated at 256 psi and class 300 at 675 psi.

In laymen's terms, just because a valve is rated at 250, it does not require ANSI class 250 flanges. In reality, the most important question regarding the flanges on our valves is its' ability to mate with the other flanges in the piping system. This is governed by the flange outside dimension, number & size of bolts holes.

Typically, our valves thru 24" are supplied with flanges complying with ANSI B16.1 class 125 flanges. However, they are UL/FM certified at 250 psi or 300 psi. We do produce specials with B16.1 class 250 or B16.5 class 300 flanges, but that does not increase the UL/FM ratings.

Flat-faced flanges can be mated with raised-face flanges without compromising the pressure rating. Ring type or full-face gaskets can be used.

Standard	Class	Flange Facing	Actual Pressure Rating (12" size or smaller)	Temperature	Material
ANSI / ASME B16.1	125	Normally flat faced, optional RF	184 psi	100 deg. C	gray cast iron
* AWWA C110 / C115	125	Normally flat faced, optional RF	350 psi	100 deg. F	ductile iron
ANSI / ASME B16.5	150	Normally raised face, optional FF	256 psi	100 deg. C	steel
ANSI / ASME B16.42	150	Normally raised face, optional FF	250 psi	100 deg. F	ductile iron
ANSI / ASME B16.1	250	Normally raised face, optional FF	448 psi	100 deg. C	gray cast iron
ANSI / ASME B16.5	300	Normally raised face, optional FF	675 psi	100 deg. C	steel
ANSI / ASME B16.42	300	Normally raised face, optional FF	650 psi	100 deg. F	ductile iron

Standard	Class	Drilling Compatibility	
ANSI / ASME B16.1	125	ANSI / ASME B16.5 class 150	ANSI / ASME B16.42 class 150
ANSI / ASME B16.5	150	ANSI / ASME B16.1 class 125	ANSI / ASME B16.42 class 150
ANSI / ASME B16.42	150	ANSI / ASME B16.1 class 125	ANSI / ASME B16.5 class 150
ANSI / ASME B16.1	250	ANSI / ASME B16.5 class 300	ANSI / ASME B16.42 class 300
ANSI / ASME B16.5	300	ANSI / ASME B16.1 class 250	ANSI / ASME B16.42 class 300
ANSI / ASME B16.42	300	ANSI / ASME B16.1 class 250	ANSI / ASME B16.5 class 300

\*United flange fittings and valves are produced in ductile iron.

## FLANGE DETAILS - ANSI B16.1 Class 125 / ANSI B16.5 Class 150

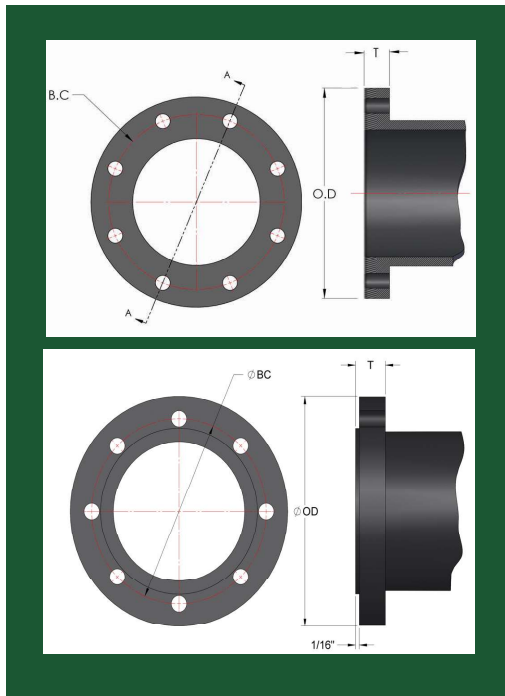

Size	O.D.	B.C.	T (min.) Class 125	T (min.) Class 150	Bolt Hole Dia.	Bolt Dia. & Length	No. of Bolts
2	6.00	4.75	0.62	0.69	3/4	5/8 x 2-1/2	4
2-1/2	7.00	5.50	0.69	0.81	3/4	5/8 x 2-1/2	4
3	7.50	6.00	0.75	0.88	3/4	5/8 x 2-1/2	4
4	9.00	7.50	0.94	0.88	3/4	5/8 x 3	8
5	10.00	8.50	0.94	0.88	7/8	3/4 x 3-1/2	8
6	11.00	9.50	1.00	0.94	7/8	3/4 x 3-1/2	8
8	13.50	11.75	1.12	1.06	7/8	3/4 x 3-1/2	8
10	16.00	14.25	1.19	1.12	1	7/8 x 4	12
12	19.00	17.00	1.25	1.19	1	7/8 x 4	12
14	21.00	18.75	1.38	1.31	1-1/8	1 x 4-1/2	12
16	23.50	21.25	1.44	1.38	1-1/8	1 x 4-1/2	16
18	25.00	22.75	1.56	1.50	1-1/4	1-1/8 x 5	16
20	27.50	25.00	1.69	1.62	1-1/4	1-1/8 x 5	20
24	32.00	29.50	1.88	1.81	1-3/8	1-1/4 x 5-1/2	20
30	38.75	36.00	2.12	-	1-3/8	1-1/4 x 6-1/2	28
36	46.00	42.75	2.38	-	1-5/8	1-1/2 x 7	32
42	53.00	49.50	2.62	-	1-5/8	1-1/2 x 7-1/2	36
48	59.50	56.00	2.75	-	1-5/8	1-1/2 x 8	44

## FLANGE DETAILS - ANSI B16.1 Class 250 / ANSI B16.5 Class 300

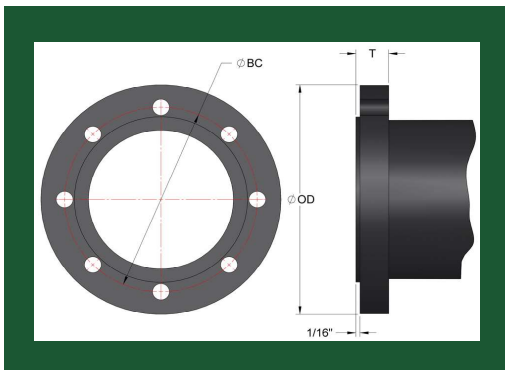

Size	OD	T (min) Class 250	T (min) Class 300	BC	Bolt Hole Dia.	Bolt Dia. & Length	No. of Bolts
2	6.50	0.88	0.81	5.00	3/4	5/8 x 3	8
2-1/2	7.50	1.00	0.94	5.88	7/8	5/8 x 3	8
3	8.25	1.12	1.06	6.62	7/8	3/4 x 3-1/2	8
4	10.00	1.25	1.19	7.88	7/8	3/4 x 4	8
5	11.00	1.38	1.31	9.25	7/8	3/4 x 4	8
6	12.50	1.44	1.38	10.62	7/8	3/4 x 4	12
8	15.00	1.62	1.56	13.00	1	7/8 x 4-1/2	12
10	17.50	1.88	1.81	15.25	1-1/8	1 x 5-1/2	16
12	20.50	2.00	1.94	17.75	1-1/4	1-1/8 x 5-1/2	16
14	23.00	2.12	2.06	20.25	1-1/4	1-1/8 x 6	20
16	25.50	2.25	2.19	22.50	1-3/8	1-1/4 x 6-1/2	20
18	28.00	2.38	2.31	24.75	1-3/8	1-1/4 x 6-1/2	24
20	30.50	2.50	2.44	27.00	1-3/8	1-1/4 x 7	24
24	36.00	2.75	2.69	32.00	1-5/8	1-1/2 x 7-1/2	24

### NOTE:

Bolt holes shall be arranged symmetrically about the vertical centerline through the flange faces. In the case of tees, this vertical centerline is defined with the face of the branch flange held parallel to the vertical plane.





All bolts, nuts and gaskets are sold in sets or box quantities.

## Non-Asbestos Flange Accessory Packs Full Face/Ring Type

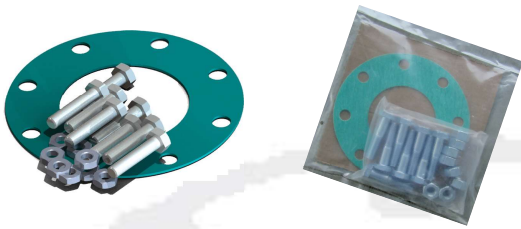

## Red Rubber Flange Accessory Packs Full Face/Ring Type



Flange Size	1/16" Full Face Non-Asbestos	1/16" Ring Type Non-Asbestos
1"	FNP-010-*	RNP-010-*
1-1/4"	FNP-012-*	RNP-012-*
1-1/2"	FNP-015-*	RNP-015-*
2"	FNP-020-*	RNP-020-*
2-1/2"	FNP-025-*	RNP-025-*
3"	FNP-030-*	RNP-030-*
4"	FNP-040-*	RNP-040-*
5"	FNP-050-*	RNP-050-*
6"	FNP-060-*	RNP-060-*
8"	FNP-080-*	RNP-080-*
10"	FNP-100-*	RNP-100-*
12"	FNP-120-*	RNP-120-*
14"	FNP-140-*	RNP-140-*
16"	FNP-160-*	RNP-160-*
18"	FNP-180-*	RNP-180-*
20"	FNP-200-*	RNP-200-*
24"	FNP-240-*	RNP-240-*
30"	FNP-300-*	RNP-300-*
36"	FNP-360-*	RNP-360-*
42"	FNP-420-*	RNP-420-*
48"	FNP-480-*	RNP-480-*

Flange Size	1/8" Full Face Red Rubber	1/8" Ring Type Red Rubber
1"	FRP-010-*	RRP-010-*
1-1/4"	FRP-012-*	RRP-012-*
1-1/2"	FRP-015-*	RRP-015-*
2"	FRP-020-*	RRP-020-*
2-1/2"	FRP-025-*	RRP-025-*
3"	FRP-030-*	RRP-030-*
4"	FRP-040-*	RRP-040-*
5"	FRP-050-*	RRP-050-*
6"	FRP-060-*	RRP-060-*
8"	FRP-080-*	RRP-080-*
10"	FRP-100-*	RRP-100-*
12"	FRP-120-*	RRP-120-*
14"	FRP-140-*	RRP-140-*
16"	FRP-160-*	RRP-160-*
18"	FRP-180-*	RRP-180-*
20"	FRP-200-*	RRP-200-*
24"	FRP-240-*	RRP-240-*
30"	FRP-300-*	RRP-300-*
36"	FRP-360-*	RRP-360-*
42"	FRP-420-*	RRP-420-*
48"	FRP-480-*	RRP-480-*

## Seal-Tite Flange Accessory Packs Full Face/Ring Type

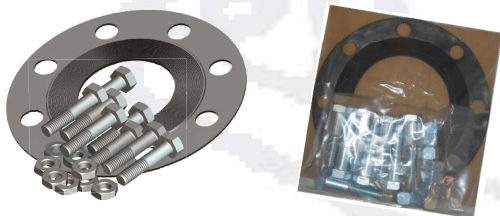

Flange Size	1/8" Full Face Seal-Tite	1/8" Ring Type Seal-Tite
2"	FBR-020-*	RBP-020-*
2-1/2"	FBR-025-*	RBP-025-*
3"	FBR-030-*	RBP-030-*
4"	FBR-040-*	RBP-040-*
5"	FBR-050-*	RBP-050-*
6"	FBR-060-*	RBP-060-*
8"	FBR-080-*	RBP-080-*
10"	FBR-100-*	RBP-100-*
12"	FBR-120-*	RBP-120-*
14"	FBR-140-*	RBP-140-*
16"	FBR-160-*	RBP-160-*
18"	FBR-180-*	RBP-180-*
20"	FBR-200-*	RBP-200-*
24"	FBR-240-*	RBP-240-*

- \*Add suffix "Z" for Zinc Plated Carbon Steel
- \*Add suffix "G" for Hot Dipped Galvanized Carbon Steel
- \*Add suffix "304" for Stainless Steel 304
- \*Add suffix "316" for Stainless Steel 316
- \*Add suffix "250" for Zinc Class 250 Flange Accessories

## Packaged Carbon Steel & Stainless Steel Hex Head Bolt & Nut Packs



Class 125/150 Flange Size	Material			Bolt Diameter and Length	No. of Bolts per Poly Bag	Master Box (Qty. of Sets)
	Part No. Carbon Steel	Part No. SS 304	Part No. SS316			
1 1-1/4 1-1/2	FBZ015-*	-	-	1/2 x 2	4	64
2 2-1/2 3	FBZ03-*	FBS03-304	FBS03-316	5/8 x 2-1/2	4	20
4	FBZ04-*	FBS04-304	FBS04-316	5/8 x 3	8	16
5 6 8	FBZ08-*	FBS08-304	FBS08-316	3/4 x 3-1/2	8	8
10 12	FBZ12-*	FBS12-304	FBS12-316	7/8 x 4	12	4
					No of Bolts per Box	No. of Boxes for one flange
14	FBZ14-*	FBS14-304	FBS14-316	1 x 4-1/2	12	1
16	FBZ16-*	FBS16-304	FBS16-316	1 x 4-1/2	16	1
18	FBZ18-*	FBS18-304	FBS18-316	1-1/8 x 5	16	1
20	FBZ20-*	FBS20-304	FBS20-316	1-1/8 x-5	20	1
24	FBZ24-*	FBS24-304	FBS24-316	1-1/4 x 5-1/2	20	1
30	FBZ30-*	FBS30-304	FBS30-316	1-1/4 x 6-1/2	14	2 boxes
36	FBZ36-*	FBS36-304	FBS36-316	1-1/2 x 7	8	4 boxes
42	FBZ42-*	FBS42-304	FBS42-316	1-1/2 x 7-1/2	9	4 boxes
48	FBZ48-*	FBS48-304	FBS48-316	1-1/2 x 8	11	4 boxes

\*Add suffix "G" for Hot Dipped Galvanized Carbon Steel

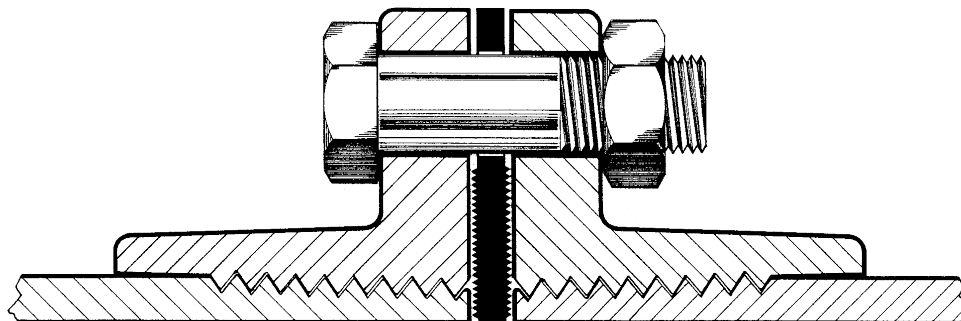

## Packaged Stud Bolt & Nut Packs



Flange Size	Material			Bolt Size	No. of Bolts/Nuts per Flange	No. of Bolts/ Nuts per Polybag	Master Box (No. of Packs)
	Part No. Carbon Steel	Part No. SS304	Part No. SS316				
2"	FSB03	FSB03-304	FSB03-316	5/8" x 3"	4	4	20
2-1/2"							
3"							
4"	FSB04	FSB04-304	FSB04-316	5/8" x 3"	8	8	16
5"	FSB08	FSB08-304	FSB08-316	3/4" x 3-1/2"	8	8	8
6"							
8"							
10"	FSB12	FSB12-304	FSB12-316	7/8" x 3-1/2"	12	12	4
12"							
14"	FSB14	FSB14-304	FSB14-316	1" x 4"	12	12	1
16"	FSB16	FSB16-304	FSB16-316	1" x 4"	16	16	1
18"	FSB18	FSB18-304	FSB18-316	1-1/8" x 4-1/2"	16	16	1
20"	FSB20	FSB20-304	FSB20-316	1-1/8" x 4-1/2"	20	20	1
24"	FSB24	FSB24-304	FSB24-316	1-1/4" x 5"	20	20	1
30"	FSB30	FSB30-304	FSB30-316	1-1/4" x 5"	28	14	2 boxes (1 pack each box)
36"	FSB36	FSB36-304	FSB36-316	1-1/2" x 6"	32	8	4 boxes (1 pack each box)
42"	FSB42	FSB42-304	FSB42-316	1-1/2" x 6"	36	9	4 boxes (1 pack each box)
48"	FSB48	FSB48-304	FSB48-316	1-1/2" x 7"	44	11	4 boxes (1 pack each box)





## Stainless Steel Hex Bolts and Nuts For ANSI Flanges

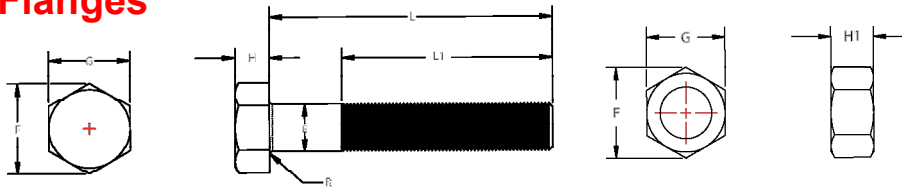

Nominal Size	Part No.	Threads per inch UNC	E	G	F	H	HI	R	L <sub>1</sub>	L
			Shaft Diameter	Width Across Flats	Max. Width Across Corners	Bolt Head Height	Nut Height	Radius of Fillet	Thread Length	Shaft Length
1/2 x 2	BN6025-050-200*	13	0.515	3/4	0.866	11/32	7/16	0.01~0.03	1.25	2.00
5/8 x 2-1/2	BN6025-062-250*	11	0.642	15/16	1.083	27/64	35/64	0.02~0.06	1.50	2.50
5/8 x 3	BN6025-062-300*	11	0.642	15/16	1.083	27/64	35/64	0.02~0.06	1.50	3.00
3/4 x 3-1/2	BN6025-075-350*	10	0.768	1-1/8	1.299	1/2	41/64	0.02~0.06	1.75	3.50
3/4 x 4-1/2	BN6025-075-450*	10	0.768	1-1/8	1.299	1/2	41/64	0.02~0.06	1.75	4.50
7/8 x 4	BN6025-082-400*	9	0.895	1-5/16	1.516	37/64	3/4	0.02~0.06	2.00	4.00
7/8 x 4-1/2	BN6025-082-450*	9	0.895	1-5/16	1.516	37/64	3/4	0.02~0.06	2.00	4.50
1 x 4-1/2	BN6025-100-450*	8	1.022	1-1/2	1.732	43/64	55/64	0.03~0.09	2.25	4.50
1-1/8 x 5	BN6025-112-500*	8	1.149	1-11/16	1.949	3/4	31/32	0.03~0.09	2.50	5.00
1-1/8 x 5-1/2	BN6025-112-550*	8	1.149	1-11/16	1.949	3/4	1-1/16	0.03~0.09	2.50	5.50
1-1/4 x 6-1/2	BN6025-125-650*	8	1.277	1-7/8	2.165	27/32	1-9/32	0.03~0.09	2.75	6.50
1-1/2 x 7	BN6025-150-700*	8	1.531	2-1/4	2.598	1	1-9/32	0.03~0.09	3.25	7.00
1-1/2 x 7-1/2	BN6025-150-750*	8	1.531	2-1/4	2.598	1	1-9/32	0.03~0.09	3.25	7.50
1-1/2 x 8	BN6025-150-800*	8	1.531	2-1/4	2.598	1	1-9/32	0.03~0.09	3.25	8.00

\* Diameters 1-1/8" and larger are UNC8 \*Add suffix 304 or 316 to specify stainless steel type.

1. ASTM A307 Grade A Carbon Steel Bolts
2. Hex head stainless steel bolts to ANSI B18.2.1 with hex stainless steel nuts to ANSI B18.2.2. Bolts to be threaded to ANSI B1.1 unified inch screw threads, Class 2A external & Class 2B internal. The stainless steel material is available in either Type 304 or Type 316.

## Hex Bolts and Nuts For ANSI Flanges

Nominal Size	Part No.	Threads per inch UNC	E	G	F	H	HI	R	L <sub>1</sub>	L
			Shaft Diameter	Width Across Flats	Max. Width Across Corners	Bolt Head Height	Nut Height	Radius of Fillet	Thread Length	Shaft Length
1/2 x 2	BN7025-050-200*	13	0.515	3/4	0.866	11/32	7/16	0.01~0.03	1.25	2.00
5/8 x 2-1/2	BN7025-062-250*	11	0.642	15/16	1.083	27/64	35/64	0.02~0.06	1.50	2.50
5/8 x 3	BN7025-062-300*	11	0.642	15/16	1.083	27/64	35/64	0.02~0.06	1.50	3.00
3/4 x 3-1/2	BN7025-075-350*	10	0.768	1-1/8	1.299	1/2	41/64	0.02~0.06	1.75	3.50
3/4 x 4-1/2	BN7025-075-450*	10	0.768	1-1/8	1.299	1/2	41/64	0.02~0.06	1.75	4.50
7/8 x 4	BN7025-082-400*	9	0.895	1-5/16	1.516	37/64	3/4	0.02~0.06	2.00	4.00
7/8 x 4-1/2	BN7025-082-450*	9	0.895	1-5/16	1.516	37/64	3/4	0.02~0.06	2.00	4.50
1 x 4-1/2	BN7025-100-450*	8	1.022	1-1/2	1.732	43/64	55/64	0.03~0.09	2.25	4.50
1-1/8 x 5	BN7025-112-500*	8	1.149	1-11/16	1.949	3/4	31/32	0.03~0.09	2.50	5.00
1-1/8 x 5-1/2	BN7025-112-550*	8	1.149	1-11/16	1.949	3/4	1-1/16	0.03~0.09	2.50	5.50
1-1/4 x 6-1/2	BN7025-125-650*	8	1.277	1-7/8	2.165	27/32	1-9/32	0.03~0.09	2.75	6.50
1-1/2 x 7	BN7025-150-700*	8	1.531	2-1/4	2.598	1	1-9/32	0.03~0.09	3.25	7.00
1-1/2 x 7-1/2	BN7025-150-750*	8	1.531	2-1/4	2.598	1	1-9/32	0.03~0.09	3.25	7.50
1-1/2 x 8	BN7025-150-800*	8	1.531	2-1/4	2.598	1	1-9/32	0.03~0.09	3.25	8.00

\* Diameters 1-1/8" and larger are UNC8 \*Add suffix "Z" for Zinc Plated Carbon Steel or "G" for Hot Dipped Galvanized Carbon Steel

1. Hex head steel bolts to ANSI B18.2.1 with hex steel nuts to ANSI B18.2.2. Bolts to be threaded to ANSI B1.1 unified inch screw threads, class 2A external & Class 2B internal. The steel material to conform to ASTM A307 specification for carbon steel externally threaded standard fasteners, Grade B.
2. Zinc Plated bolts - ASTM B633

# Stud Bolt/Nut Details

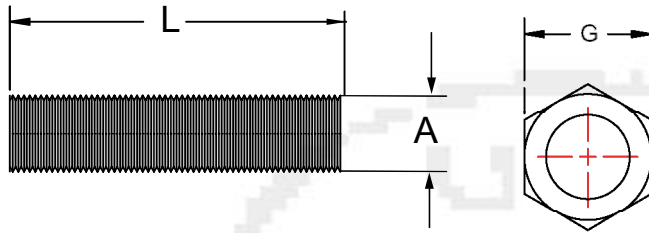

## Material Standard:

### Bolts:

Zinc Plated Steel, ASTM A193 Grade B7  
 Stainless Steel 304  
 Stainless Steel 316

### Nuts:

Zinc Plated Steel, ASTM A194 Grade 2H  
 Stainless Steel 304  
 Stainless Steel 316

## Thread Standard:

### Bolts:

ANSI B18.2.1  
 UNC, Class 2A

### Nuts:

ANSI B18.22  
 UNC, Class 2B

For use with Flange Pipe

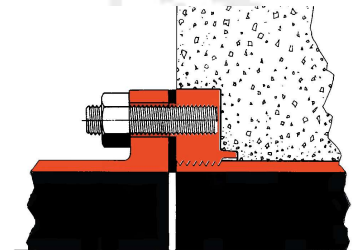

STUD BOLTS				NUTS			
Bolt Size A/L	Part No. Zinc Plated (B7)	Part No. SS304	Part No. SS316	Nut Size	Part No. Zinc Plated (2H)	Part No. SS304	Part No. SS316
1/2" x 2"	8025-050-200	8025-050-200-304	8025-050-200-316	1/2"	8035-050	8035-050-304	8035-050-316
5/8" x 2-1/2"	8025-062-250	8025-062-250-304	8025-062-250-316	5/8"	8035-062	8035-062-304	8035-062-316
5/8" x 3"	8025-062-300	8025-062-300-304	8025-062-300-316				
5/8" x 3-1/2"	8025-062-350	8025-062-350-304	8025-062-350-316				
5/8" x 6"	8025-062-600	8025-062-600-304	8025-062-600-316				
3/4" x 3"	8025-075-300	8025-075-300-304	8025-075-300-316	3/4"	8035-075	8035-075-304	8035-075-316
3/4" x 3-1/2"	8025-075-350	8025-075-350-304	8025-075-350-316				
3/4" x 4"	8025-075-400	8025-075-400-304	8025-075-400-316				
3/4" x 4-1/2"	8025-075-450	8025-075-450-304	8025-075-450-316				
3/4" x 5"	8025-075-500	8025-075-500-304	8025-075-500-316				
3/4" x 5-1/2"	8025-075-550	8025-075-550-304	8025-075-550-316				
3/4" x 6"	8025-075-600	8025-075-600-304	8025-075-600-316				
3/4" x 7"	8025-075-700	8025-075-700-304	8025-075-700-316				
7/8" x 3-1/2"	8025-082-350	8025-082-350-304	8025-082-350-316	7/8"	8035-082	8035-082-304	8035-082-316
7/8" x 3-3/4"	8025-082-375	8025-082-375-304	8025-082-375-316				
7/8" x 8"	8025-082-800	8025-082-800-304	8025-082-800-316				
1" x 4"	8025-100-400	8025-100-400-304	8025-100-400-316	1"	8035-100	8035-100-304	8035-100-316
1" x 5"	8025-100-500	8025-100-500-304	8025-100-500-316				
1" x 6"	8025-100-600	8025-100-600-304	8025-100-600-316				
1-1/8" x 4-1/2"	8025-112-450	8025-112-450-304	8025-112-450-316	1-1/8"	8035-112	8035-112-304	8035-112-316
1-1/8" x 5"	8025-112-500	8025-112-500-304	8025-112-500-316				
1-1/4" x 5"	8025-125-500	8025-125-500-304	8025-125-500-316	1-1/4"	8035-125	8035-125-304	8035-125-316
1-1/4" x 6"	8025-125-600	8025-125-600-304	8025-125-600-316				
1-1/4" x 7"	8025-125-700	8025-125-700-304	8025-125-700-316				
1-1/2" x 6"	8025-150-600	8025-150-600-304	8025-150-600-316	1-1/2"	8035-150	8035-150-304	8035-150-316
1-1/2" x 7"	8025-150-700	8025-150-700-304	8025-150-700-316				

Threads: 1" Diameter and smaller - Unified inch course (UNC), Class 2A  
 1-1/8" Diameter and larger - Unified inch 8 thread series (UN 8) Class 2A

## Washers - USS flat type - Zinc Plate Steel

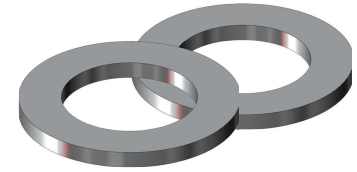

Why use flat washers with flange joints?

Washers provide three important roles:

- Firstly, they provide a smooth surface and distribute the pressure of the bolt and nut evenly.
- Secondly, by eliminating friction, the wrench torque required is reduced by providing a smooth surface in lieu of a rough-cast back of flange surface.
- Thirdly, they protect special coatings, for example Fusion bonded epoxy coatings. Tightening hex bolts and nuts on these surfaces without washers can damage or remove those coatings.

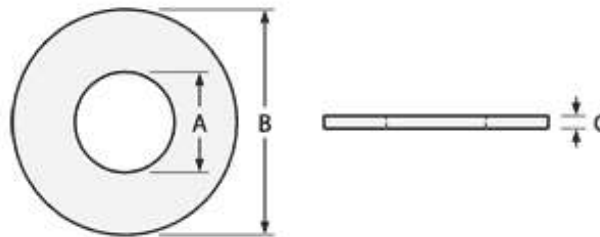

Bolt Size	Washer Size	I.D. (A)	O.D. (B)	Thickness (C)	Bag Qty.	Box Qty.
1/2"	1/2"	9/16"	1-3/8"	0.109"	100	1000
5/8"	5/8"	11/16"	1-3/4"	0.134"	100	1000
3/4"	3/4"	13/16"	2"	0.148"	50	500
7/8"	7/8"	15/16"	2-1/4"	0.165"	25	250
1"	1"	1-1/16"	2-1/2"	0.165"	25	250
1-1/8"	1-1/4"	1-1/4"	2-3/4"	0.165"	25	250
1-1/4"	1-1/4"	1-3/8"	3"	0.165"	25	250
1-1/2"	1-1/2"	1-5/8"	3-1/2"	0.180"	25	250

Dimensional Standard: ASME 18.21.1



# **Butterfly Valve Lug/Wafer Bolting**

# Recommended Bolt Lengths

## For use with Lug Type Butterfly Valve - Model 2400-L

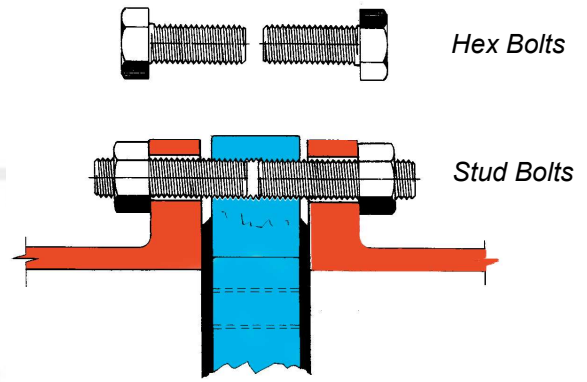

Class 125								
Valve Size	2"	2-1/2"	3"	4"	6"	8"	10"	12"
No. of Bolts	4	4	4	8	8	8	12	12
Bolt Size	5/8"-UNC	5/8"-UNC	5/8"-UNC	5/8"-UNC	3/4"-UNC	3/4"-UNC	7/8"-UNC	7/8"-UNC
Length Stud Bolts	2-1/2"	2-1/2"	2-1/2"	2-1/2"	3"	3"	3-1/2"	3-1/2"
Length Hex Bolts	1-1/2"	1-1/2"	1-1/2"	2"	2"	2"	2-1/2"	2-1/2"

## For use with Wafer Type Butterfly Valve - Model 2400-W

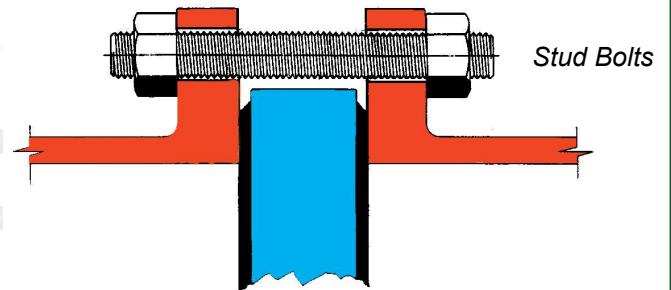

Class 125								
Valve Size	2"	2-1/2"	3"	4"	6"	8"	10"	12"
No. of Bolts	8	8	8	16	16	16	24	24
Bolt Size	5/8"-UNC	5/8"-UNC	5/8"-UNC	5/8"-UNC	3/4"-UNC	3/4"-UNC	7/8"-UNC	7/8"-UNC
Length Stud Bolts	5"	5-1/2"	5-1/2"	5-1/2"	6"	6-1/2"	7"	8"

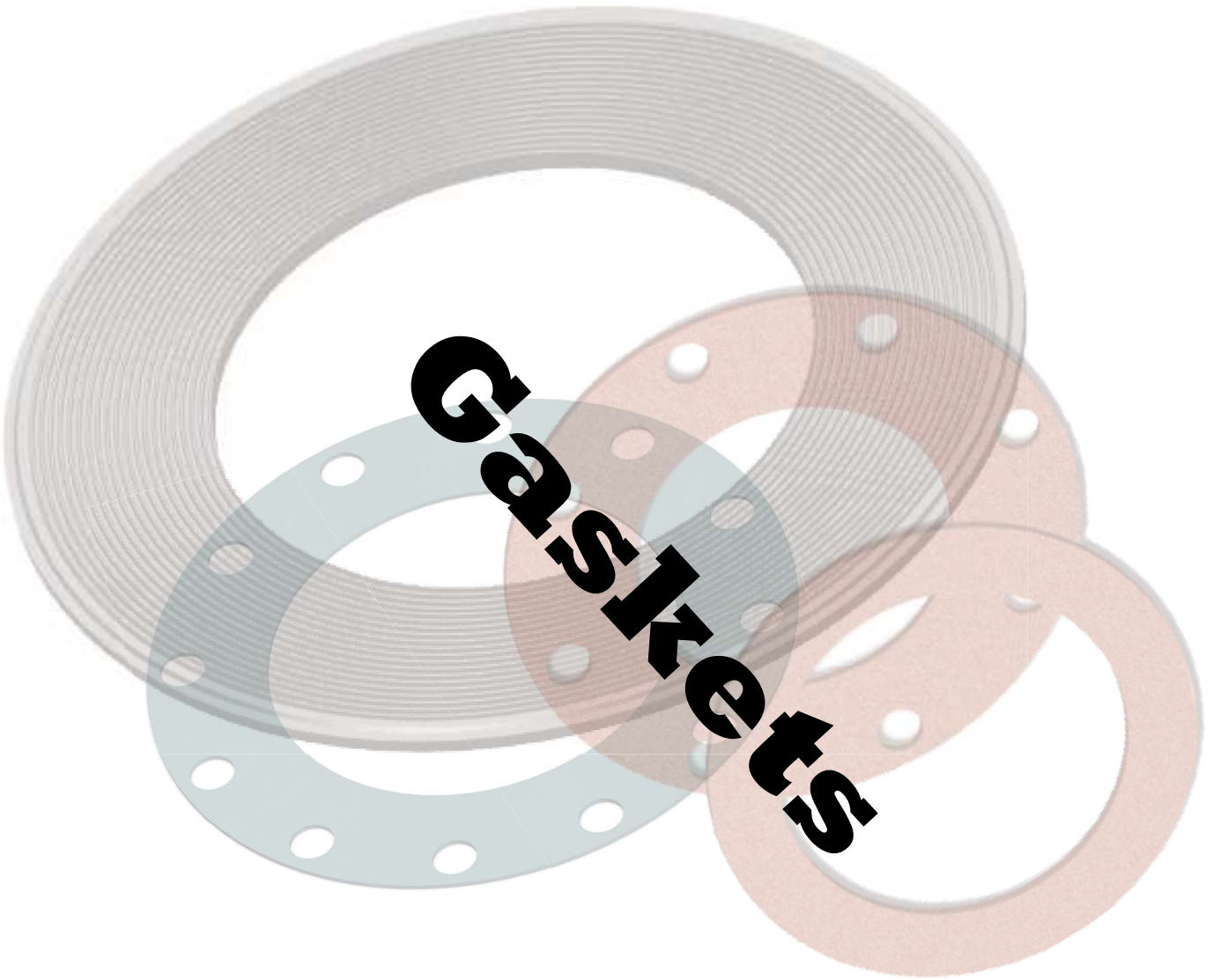

# Seal-Tite Flange Gaskets

Ideal for use with fusion bonded epoxy coated flange faces.



Ideal for use with ductile iron flanged fabricated pipes to AWWA C-115.

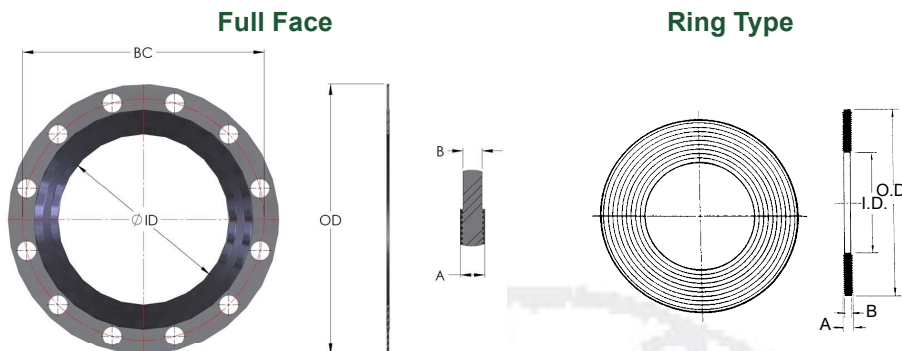

Material: SBR

Low Torque!

Nominal Size	Part No. (Full Face)	Part No. (Ring)	ID	OD (Full Face)	OD (Ring)	A	B	BC (Full Face)	Box Quantity (Full Face)	Box Quantity (Ring)
2	FFG-050-150	RG-050-100	2.15	6.00	3.90	5/32	1/8	4.75	25	25
2 1/2	FFG-065-175	RG-065-120	2.73	7.00	4.70	5/32	1/8	5.50	25	25
3	FFG-080-188	RG-080-132	3.20	7.50	5.15	5/32	1/8	6.00	25	25
4	FFG-100-210	RG-100-162	3.98	9.00	6.30	5/32	1/8	7.50	25	25
5	FFG-125-250	RG-125-194	5.07	10.00	7.60	5/32	1/8	8.50	25	25
6	FFG-150-275	RG-150-218	6.01	11.00	8.50	5/32	1/8	9.50	25	25
8	FFG-200-340	RG-200-272	8.11	13.50	10.60	5/32	1/8	11.75	25	25
10	FFG-250-400	RG-250-328	10.06	16.00	12.80	5/32	1/8	14.25	25	25
12	FFG-300-475	RG-300-378	12.09	19.00	14.75	5/32	1/8	17.00	10	10
14	FFG-350-525	RG-350-445	14.12	21.00	17.15	5/32	1/8	18.75	10	10
16	FFG-400-588	RG-400-510	16.19	23.50	19.90	5/32	1/8	21.25	10	10
18	FFG-450-625	RG-450-542	18.25	25.00	21.15	5/32	1/8	22.75	10	10
20	FFG-500-688	RG-500-606	20.28	27.50	23.60	5/32	1/8	25.00	10	10
24	FFG-600-800	RG-600-717	24.34	32.00	27.95	5/32	1/8	29.50	10	10

## Bolt Torque Requirements

Size	Working Pressure	
	250 psi WWP min. torque	350 psi WWP min. torque
3"	90 ft. lbs.	110 ft. lbs.
4"	90 ft. lbs.	110 ft. lbs.
6"	90 ft. lbs.	110 ft. lbs.
8"	90 ft. lbs.	130 ft. lbs.
10"	90 ft. lbs.	130 ft. lbs.
12"	90 ft. lbs.	130 ft. lbs.
14"	110 ft. lbs.	-
16"	110 ft. lbs.	-
18"	120 ft. lbs.	-
20"	120 ft. lbs.	-
24"	130 ft. lbs.	-

### Notes:

The Seal-Tite gasket makes contact on the machined pipe surfaces creating a positive seal between the pipe ends on ductile iron fabricated pipe, eliminating possible leakage at the threads.

**Material Standard:** SBR (styrene-butadiene rubber )  
- ASTM D3186-97

### Reference Standard:

**Full Face** - Fits ANSI B16.1 Class 125/150 Flanges

**Ring Type** - Fits ANSI B16.1 / Class ANSI B16.5  
Class 125/150/250/300 Flanges

### Temperature Rating:

-20°F or +180°F

# Red Rubber Flange Gaskets

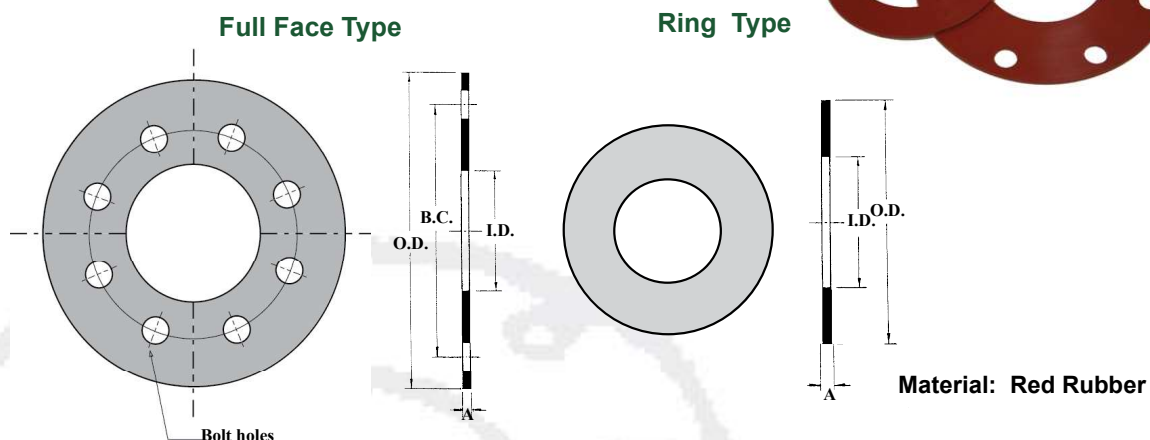

Nominal Size	Part No. (Full Face)	Part No. (Ring)	ID	OD (Full Face)	OD (Ring)	A	BC	No. of Bolt Holes	Box Qty. (Full Face)	Box Qty. (Ring)
1"	FFRG-010	RRG-010	1.31	4.25	2.63	1/8	3.12	4	25	25
1-1/4"	FFRG-012	RRG-012	1.66	4.62	3.00	1/8	3.50	4	25	25
1-1/2"	FFRG-015	RRG-015	1.91	5.00	3.38	1/8	3.62	4	25	25
2"	FFRG-020	RRG-020	2.10	6.00	3.90	1/8	4.75	4	25	25
2-1/2"	FFRG-025	RRG-025	2.60	7.00	4.70	1/8	5.50	4	25	25
3"	FFRG-030	RRG-030	3.10	7.50	5.15	1/8	6.00	4	25	25
4"	FFRG-040	RRG-040	4.10	9.00	6.30	1/8	7.50	8	25	25
5"	FFRG-050	RRG-050	5.10	10.00	7.60	1/8	8.50	8	25	25
6"	FFRG-060	RRG-060	6.10	11.00	8.50	1/8	9.50	8	25	25
8"	FFRG-080	RRG-080	8.10	13.50	10.60	1/8	11.75	8	25	25
10"	FFRG-100	RRG-100	10.10	16.00	12.80	1/8	14.25	12	25	25
12"	FFRG-120	RRG-120	12.10	19.00	14.75	1/8	17.00	12	10	10
14"	FFRG-140	RRG-140	14.20	21.00	17.15	1/8	18.75	12	10	10
16"	FFRG-160	RRG-160	16.20	23.50	19.90	1/8	21.25	16	10	10
18"	FFRG-180	RRG-180	18.20	25.00	21.15	1/8	22.75	16	10	10
20"	FFRG-200	RRG-200	20.20	27.50	23.60	1/8	25.00	20	10	10
24"	FFRG-240	RRG-240	24.20	32.00	27.95	1/8	29.50	20	10	10
30"	FFRG-300	-	30.00	38.75	-	1/8	36.00	28	5	-
36"	FFRG-360	-	36.00	46.00	-	1/8	42.75	32	5	-
42"	FFRG-420	-	42.00	53.00	-	1/8	49.50	36	5	-
48"	FFRG-480	-	48.00	59.50	-	1/8	56.00	44	5	-

## Notes:

**Material Standard:** Red Rubber Sheet - ASTM D1330, Grade 1, SBR/Durometer 65-75 Shore A/Red Color

**Reference Standard:**

**Full Face** - Fits ANSI B16.1 Class 125/150 Flanges, ANSI B16.5 Class 150

**Ring Type** - Fits ANSI B16.1 / Class ANSI B16.5 Class 125/150/250/300 Flanges

**Maximum Temp.:** 170°F (77°C)

**Minimum Temp.:** -20°F (-29°C)

**Maximum Working Pressure:** 200 PSIG

# Non-Asbestos Flange Gaskets

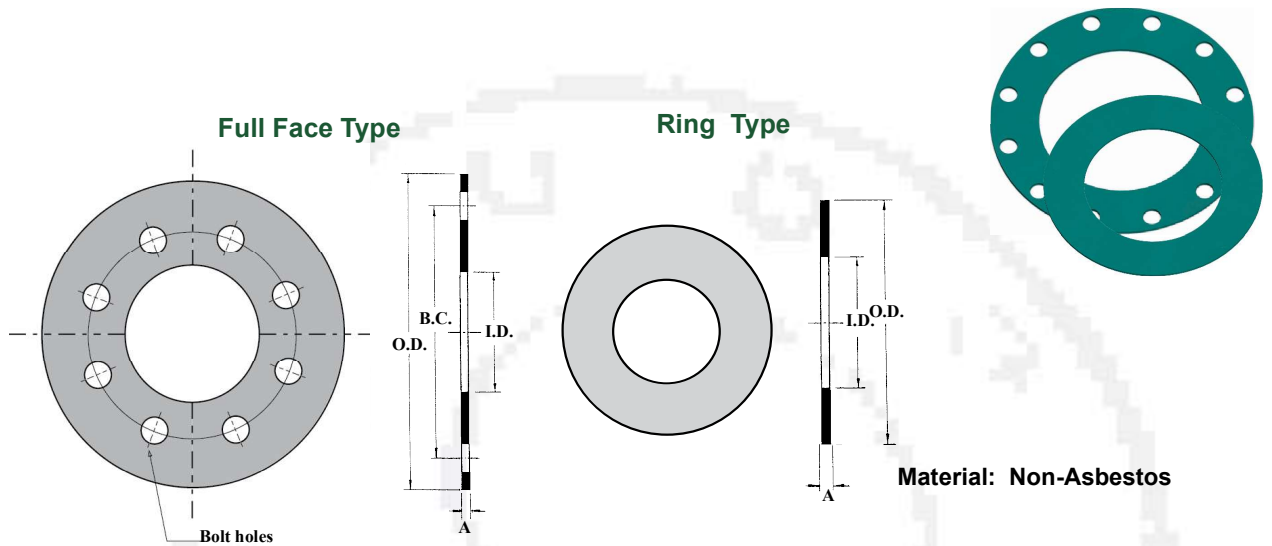

Nominal Size	Part No. (Full Face)	Part No. (Ring)	ID	OD (Full Face)	OD (Ring)	A	BC	No. of Bolt Holes	Box Qty. (Full Face)	Box Qty. (Ring)
1"	FFNG-010	RNG-010	1.31	4.25	2.63	1/16	3.12	4	25	25
1-1/4"	FFNG-012	RNG-012	1.66	4.62	3.00	1/16	3.50	4	25	25
1-1/2"	FFNG-015	RNG-015	1.91	5.00	3.38	1/16	3.62	4	25	25
2"	FFNG-020	RNG-020	2.10	6.00	3.90	1/16	4.75	4	25	25
2-1/2"	FFNG-025	RNG-025	2.60	7.00	4.70	1/16	5.50	4	25	25
3"	FFNG-030	RNG-030	3.10	7.50	5.15	1/16	6.00	4	25	25
4"	FFNG-040	RNG-040	4.10	9.00	6.30	1/16	7.50	8	25	25
5"	FFNG-050	RNG-050	5.10	10.00	7.60	1/16	8.50	8	25	25
6"	FFNG-060	RNG-060	6.10	11.00	8.50	1/16	9.50	8	25	25
8"	FFNG-080	RNG-080	8.10	13.50	10.60	1/16	11.75	8	25	25
10"	FFNG-100	RNG-100	10.10	16.00	12.80	1/16	14.25	12	25	25
12"	FFNG-120	RNG-120	12.10	19.00	14.75	1/16	17.00	12	10	10
14"	FFNG-140	RNG-140	14.20	21.00	17.15	1/16	18.75	12	10	10
16"	FFNG-160	RNG-160	16.20	23.50	19.90	1/16	21.25	16	10	10
18"	FFNG-180	RNG-180	18.20	25.00	21.15	1/16	22.75	16	10	10
20"	FFNG-200	RNG-200	20.20	27.50	23.60	1/16	25.00	20	10	10
24"	FFNG-240	RNG-240	24.20	32.00	27.95	1/16	29.50	20	10	10

## Notes:

**Material Standard:** Non-Asbestos - Synthetic fiber/nitrile binder

**Reference Standard:** ASTM F104

**Full Face** - Fits ANSI B16.1 Class 125/150 Flanges

**Ring Type** - Fits ANSI B16.1 / Class ANSI B16.5 Class 125/150/250/300 Flanges

**Maximum Temp.:** 460°F (238°C)

**Maximum Working Pressure:** 750 PSI

## ANSI BOLTS (soft conversion) for use with METRIC Flanges

### PN10 Flange

PN10 Flange Size	Flange Size (Inch)	Bolt Qty.	Metric Bolt Size mm	ANSI Bolt Size Inch (soft conversion)	Bolt & Nut Pack Product Number (inch size bolts) Zinc Plated Steel	Bolt & Nut Pack Product Number (inch size bolts) SS 304	Bolt & Nut Pack Product Number (inch size bolts) SS 316
DN50	2"	4	M16	5/8" x 2-1/2"	FBZ03	FBS03-304	FBS03-316
DN65	2-1/2"	4	M16	5/8" x 2-1/2"	FBZ03	FBS03-304	FBS03-316
DN80	3"	8	M16	5/8" x 3"	FBZ04	FBS04-304	FBS04-316
DN100	4"	8	M16	5/8" x 3"	FBZ04	FBS04-304	FBS04-316
DN125	5"	8	M16	5/8" x 3"	FBZ04	FBS04-304	FBS04-316
DN150	6"	8	M20	3/4" x 3-1/2"	FBZ08	FBS08-304	FBS08-316
DN200	8"	8	M20	3/4" x 3-1/2"	FBZ08	FBS08-304	FBS08-316
DN250	10"	12	M20	3/4" x 3-1/2"	FBZ09	FBS09-304	FBS09-316
DN300	12"	12	M20	3/4" x 3-1/2"	FBZ09	FBS09-304	FBS09-316
DN350	14"	16	M20	3/4" x 3-1/2"	FBZ10	FBS10-304	FBS10-316
DN400	16"	16	M24	7/8" x 4"	FBZ16-16	FBS16-16-304	FBS16-16-316
DN450	18"	20	M24	7/8" x 4"	FBZ16-20	FBS16-20-304	FBS16-20-316
DN500	20"	20	M24	7/8" x 4"	FBZ16-20	FBS16-20-304	FBS16-20-316
DN600	24"	20	M27	1" X 4-1/2"	FBZ17	FBS17-304	FBS17-316

### PN16 Flange

PN16 Flange Size	Flange Size (Inch)	Bolt Qty.	Metric Bolt Size mm	ANSI Bolt Size Inch (soft conversion)	Bolt & Nut Pack Product Number (inch size bolts) Zinc Plated Steel	Bolt & Nut Pack Product Number (inch size bolts) SS 304	Bolt & Nut Pack Product Number (inch size bolts) SS 316
DN50	2"	4	M16	5/8" x 2-1/2"	FBZ03	FBS03-304	FBS03-316
DN65	2-1/2"	4	M16	5/8" x 2-1/2"	FBZ03	FBS03-304	FBS03-316
DN80	3"	8	M16	5/8" x 3"	FBZ04	FBS04-304	FBS04-316
DN100	4"	8	M16	5/8" x 3"	FBZ04	FBS04-304	FBS04-316
DN125	5"	8	M16	5/8" x 3"	FBZ04	FBS04-304	FBS04-316
DN150	6"	8	M20	3/4" x 3-1/2"	FBZ08	FBS08-304	FBS08-316
DN200	8"	12	M20	3/4" x 3-1/2"	FBZ10	FBS10-304	FBS10-316
DN250	10"	12	M24	7/8" x 4"	FBZ12	FBS12-304	FBS12-316
DN300	12"	12	M24	7/8" x 4"	FBZ12	FBS12-304	FBS12-316
DN350	14"	16	M24	7/8" x 4"	FBZ13	FBS13-304	FBS13-316
DN400	16"	16	M27	1" X 4-1/2"	FBZ16	FBS16-304	FBS16-316
DN450	18"	20	M27	1" X 4-1/2"	FBZ17	FBS17-304	FBS17-316
DN500	20"	20	M30	1-1/8" X 5"	FBZ20	FBS20-304	FBS16-316
DN600	24"	20	M33	1-1/4" x 5-1/2"	FBZ24	FBS24-304	FBS24-316

For more information on our products, please **"click"** on the appropriate catalog below for your needs!

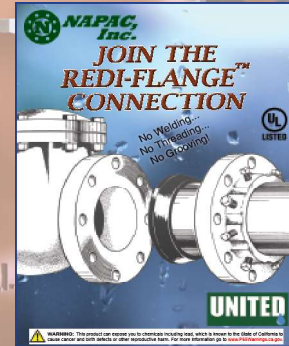
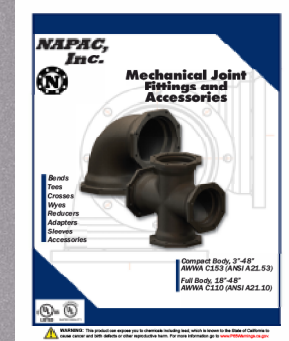

**Napac United Distribution Centers**  
229 Southbridge Street  
Worcester, MA 01608  
Tel.: (800) 807-2215  
Fax: (800) 807-2214  
[www.napacinc.com](http://www.napacinc.com)



**Distributed by:**